

Data Sheet Masking Ring

Release date : 12.03.2008

Product range : 8" - 64"

Product code : MR

Commodity / HS code : 73269098

Elskensakker 8, NL-5571 SK
Bergeijk, The Netherlands

Tel +31 497 542527

Fax +31 497 555399

Email info@dhatec.nl

Web www.dhatec.nl

Application:

The Masking Ring protects the parent coating during the field joint coating process or Jay-Lay process. After two pipes are welded together, the welding area is usually cleaned and blasted. During these procedures it is important not to damage the parent isolation, to ensure good bonding later on.

5 reasons to choose this product:

1. Fast and easy fitting and removal
2. Reusable
3. Long life time
4. Adjustable clamping system for exact fitting
5. Modifications possible according to customers' wishes

Material qualities:

Rubber profile : EPDM
Metal rings : DD 11 (Material nr: 1.0332)
Clamping system : St. 37-2 K (Material nr: 1.0037)
Hinge : C 75 (Material nr: 1.0605)

Function:

After welding two pipes together, two Masking Rings are positioned around the parent coating ends on both sides of the welding area, as shown in fig 1. The Masking Ring can be opened easily due to the flexible hinge in the back.

Additional information:

- Application temperature: -40 °C / +120 °C
- Different models available to fit any coating thickness

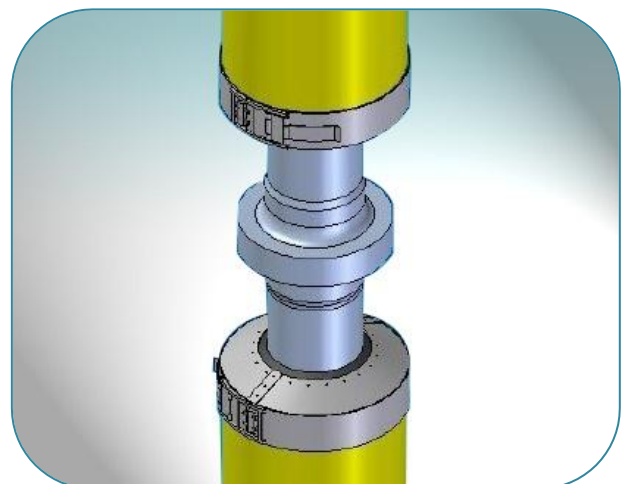

Fig 1: Application of Masking Rings



Fig 2: Masking Ring